

Heat Recovery **Power** Systems

Organic Rankine Cycle



Waste Heat Parameters

- Base load, consistent process heat
- Clean, non-corrosive gas or liquid
- High price for power and/or capacity
- Qualified for renewable energy or carbon credits
- Quality heat source
 - Gas $>350^{\circ}$ F / 180° C
 - Saturated steam
 - Liquid $>250^{\circ}$ F / 120° C
 - 200° F / 100° C may be viable



Heat Recovery Systems

- Geothermal
 - Brine Systems
- Waste Heat Recovery
 - Process Industries
 - Landfill Gas
- **Prime Movers**
 - **Gas Turbines and Engines**
 - **CHP**
 - **Power, Heat and Cooling**
- Solar Thermal



Heat Recovery Process Overview

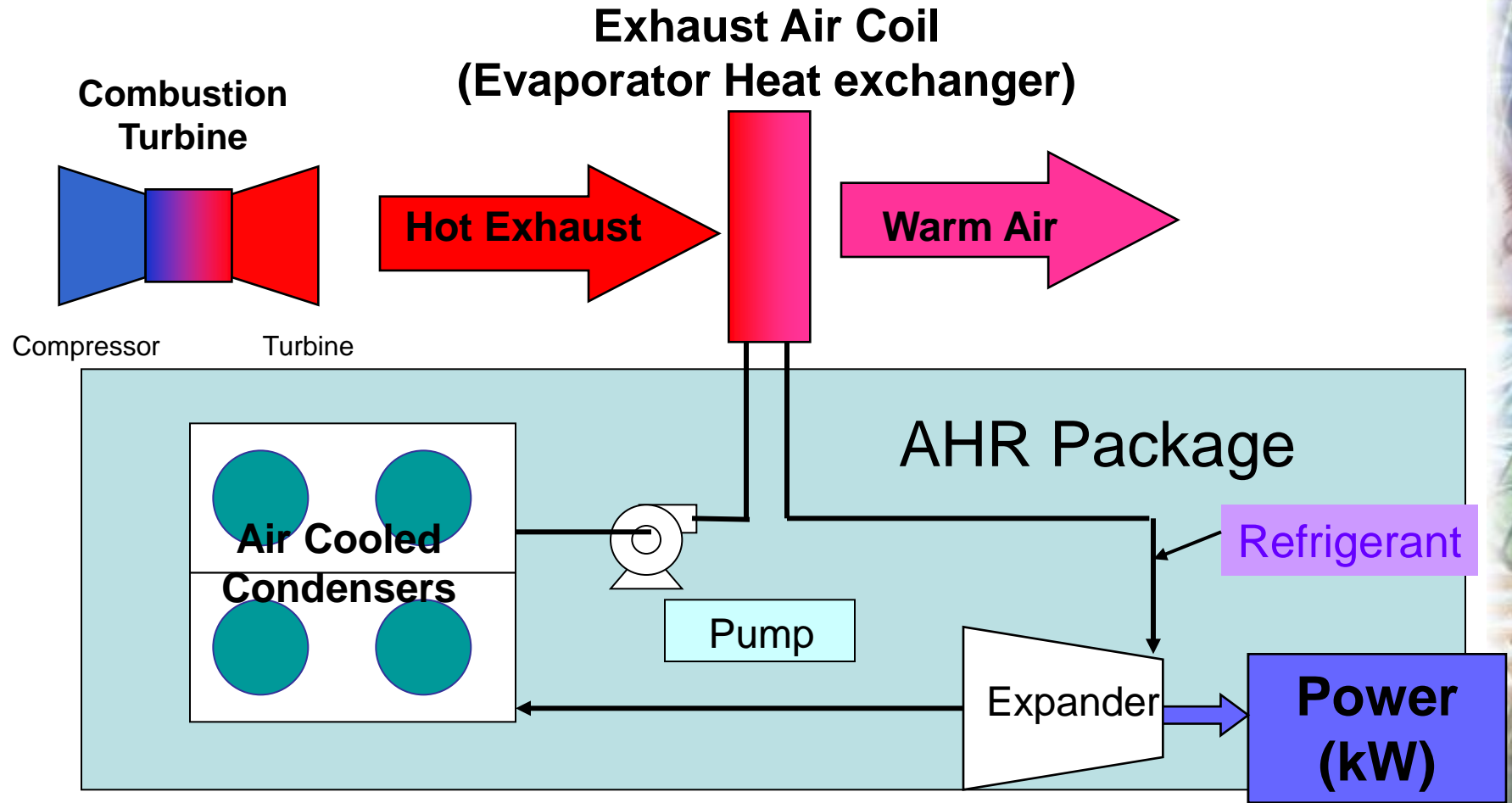

What is a CHP Plant

- Integrated Heating, Cooling and Power Generation System
- Supplies Part of the Electric Load for the Facility
- Recovers the by-product Heat from Generation and Uses it for:
 - Space Cooling (chilled water)
 - Space Heating (steam or hot water)
 - Dehumidification System



CHP – Traditional

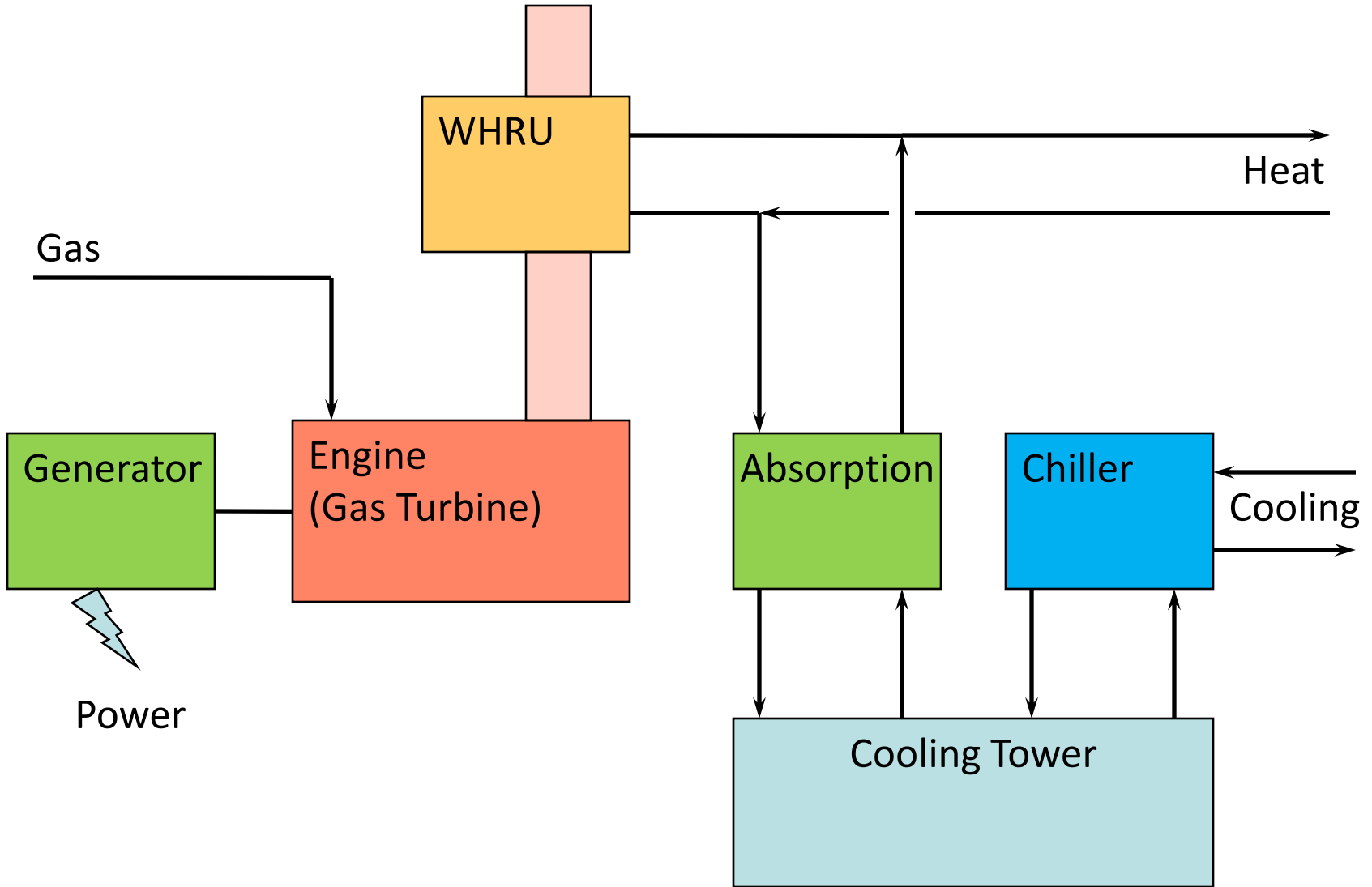

CHP – With ORC

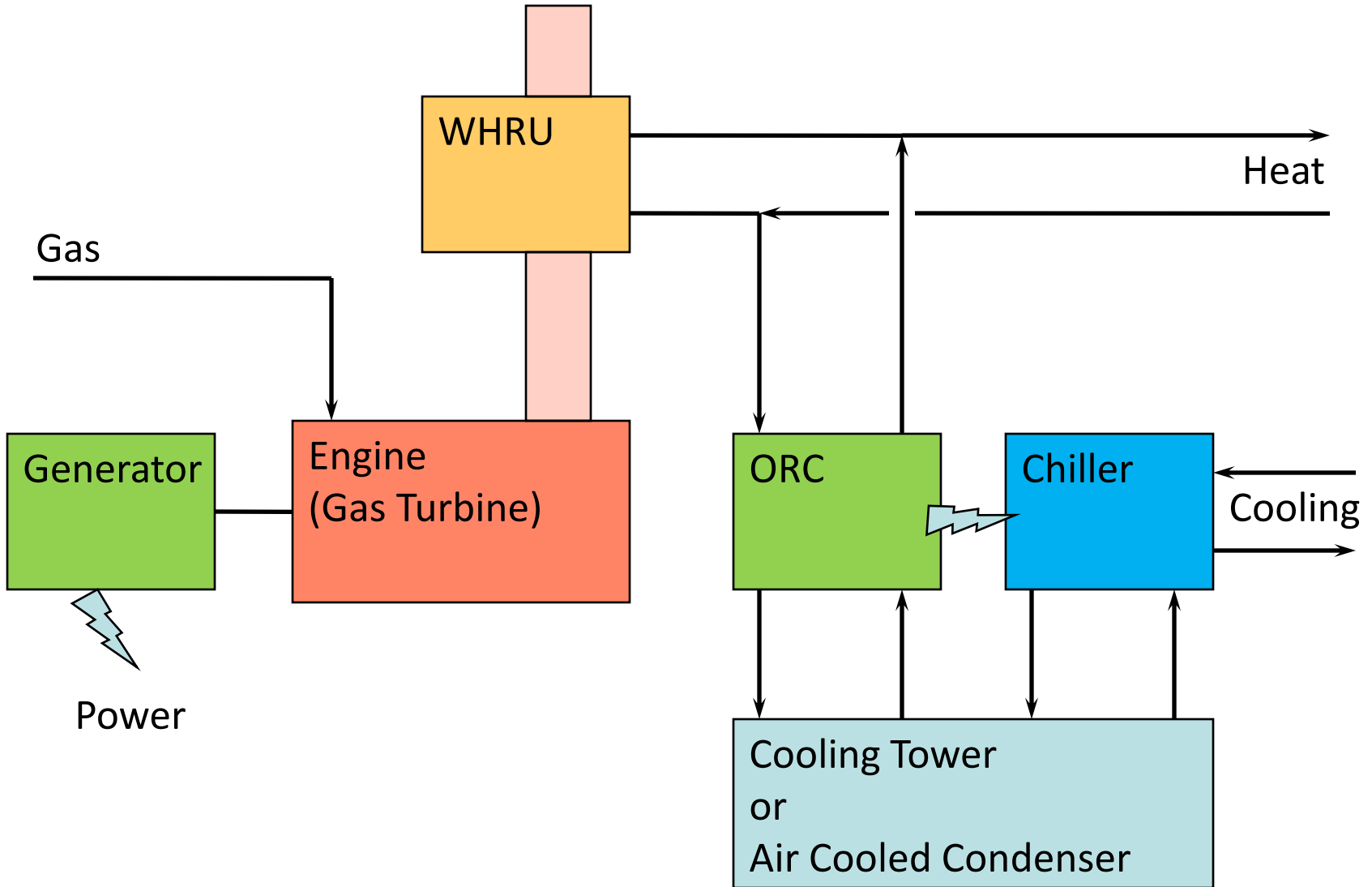

CHP – Using ORC

- Using ORC can use standard electric chillers
 - Eliminates specialist absorption technology
 - ORC is similar technology to chiller
 - Water or Air cooled
 - Air cooled not possible with absorption
- More cooling output (same heat output)
 - 5MW gas turbine generator gives:
 - Traditionally with absorption 2,000TR cooling
 - With ORC & electric chiller 3,500TR cooling
- More power output year round
 - Power more valuable than heat
 - Flexibility to choose between heat and power
- No Steam
 - Less maintenance
 - Avoids requirement for Certified Steam Operator



Heat Recovery Value Streams

- Energy and capacity savings
 - Displacement of existing energy (\$/KW.hr)
 - Reduction of capacity (\$/kW/month)
- Federal/State tax credits and incentives
 - % of capital investment (Federal 10%)
 - Various incentive programs (CA \$1000/kW)
 - Accelerate depreciation
- Emission and renewable energy credits
 - Carbon credits (\$/ton)
 - Renewable energy credits (\$/kW.hr)



Waste Heat Net Present Value

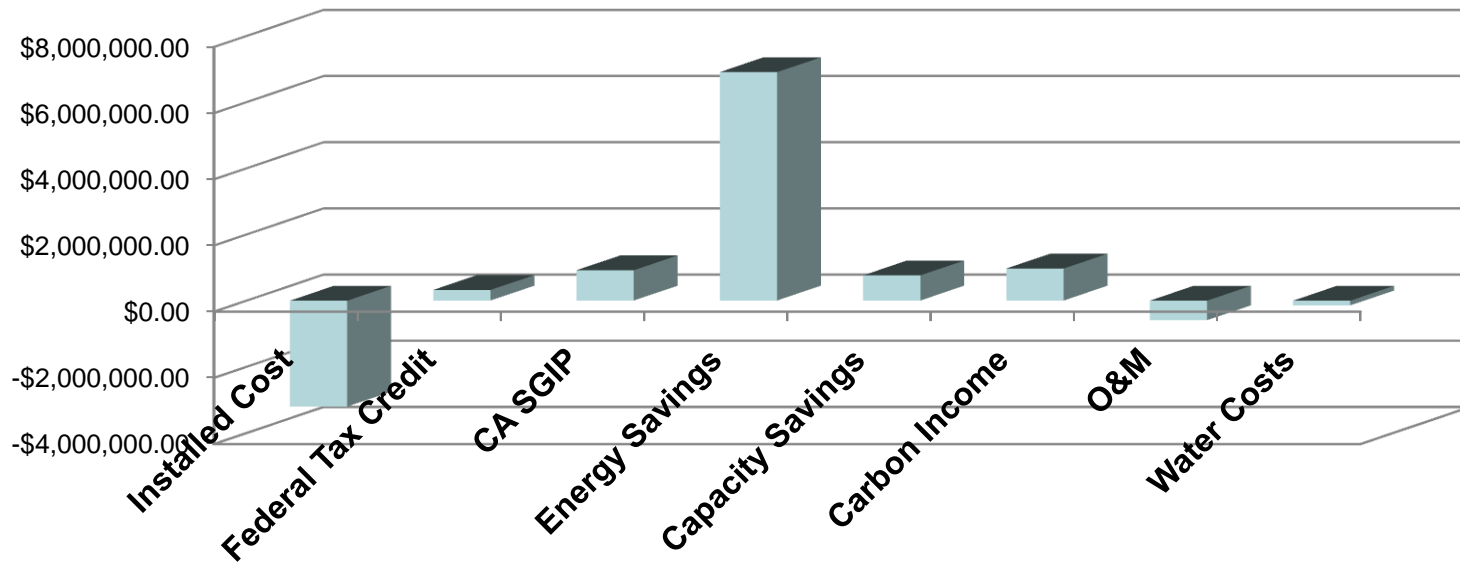

- Nominal 900kW system
- After tax **pay back three years**
- **IRR of 28.3%**

Federal Tax Credit	0.1	%
SGIP Rebate	1000	\$/KW
Capacity Savings	10	\$/KW/Month
Energy Savings	0.108	\$/KW-hr
Carbon Credits	19	\$/Ton



Waste Heat Net Present Value

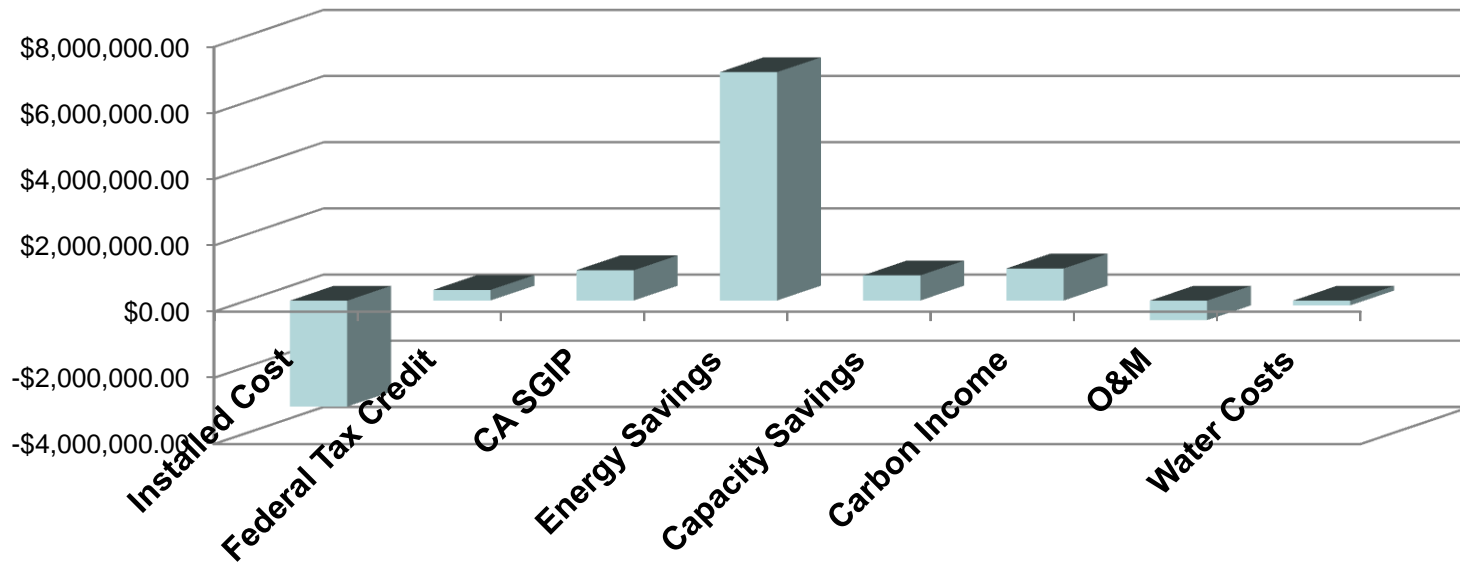

- Nominal 900kW system
- After tax **pay back three years**
- **IRR of 28.3%**

Federal Tax Credit	0.1	%
SGIP Rebate	1000	\$/KW
Capacity Savings	10	\$/KW/Month
Energy Savings	0.108	\$/KW-hr
Carbon Credits	19	\$/Ton



???

